

SMART FIXING SYSTEMS

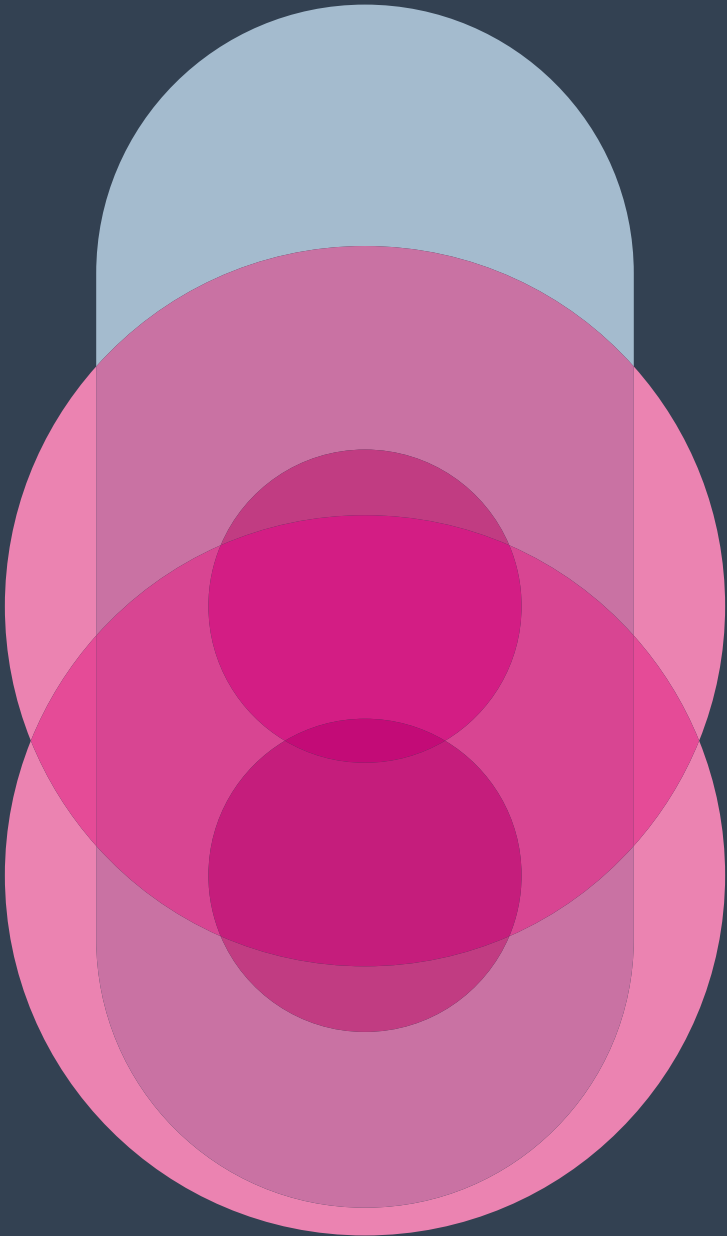



REAR-VENTILATED FACADE

The hung, rear-ventilated facade (RVF) covers the load bearing wall of a building. With a RVF, the facade elements are mounted with the help of a fixing system at a distance from the building's outside wall.

Besides the varied architectural possibilities, this method of construction has considerable ecological and economical benefits:

- The RVF protects against weather conditions and contributes to the longevity of the building. The outside wall of the building and the thermal insulation remain dry always.
- The RVF minimises thermal stress and is the optimum protection against heat and cold.
- The RVF is an energy-saving facade. The variable lengths of wall brackets make it possible to install with any desired thickness of insulation. Energy savings leads to minimisation of carbon dioxide discharge.
- Back ventilating the facade controls the humidity of the building and ensures an optimum climate inside.
- The multilayered structure of RVF protects against noise.
- The RVF system guarantees sustainable construction through recycling the components that are used.

CONSTRUCTION OF THE RVF

- 1 Load bearing wall
- 2 Insulation
- 3 Ventilation space
- 4 Facade panel
- 5 Allface substructure

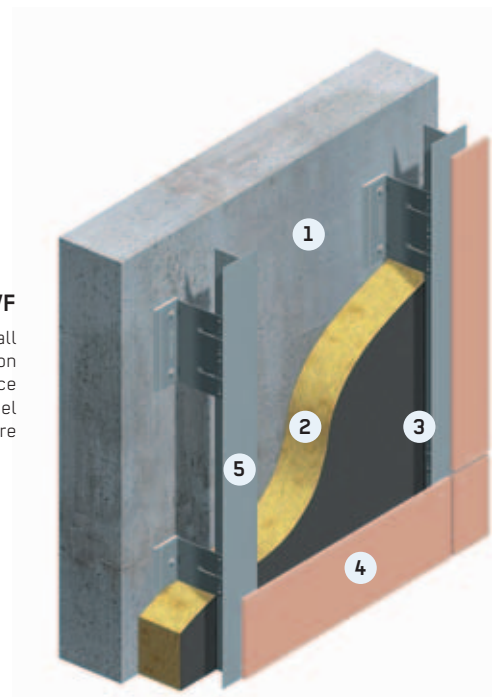

ALLFACE SMART FIXING SYSTEMS

The critical element and basis of a fixing system is the wall bracket. It decides the layout of the facade's substructure.

WALL BRACKET F1

Wall bracket F1 is used for vertical fixing on solid walls.

Technical Features/Benefits:

- Wind pressure is passed right to the building element - no tensile load on the dowel.
- Each F1 can be used for a fixed point or a sliding point.
- The F1+ is mainly used as an anchor point. It has high bearing capacity through construction height and 2 wall mountings.
- Dowel spacing of 125 mm for the F1+ makes it possible to fasten to a problematic subgrade.
- Integrated clamp-slide provides 40 mm of adjusting for the L- or T-profiles.
- Made of aluminium EN-AW 6060 T68

Wall Bracket	Overhang A	Distance to Wall B
F1.35	35 mm	42 - 80 mm
F1.50	50 mm	57 - 95 mm
F1.80	80 mm	87 - 125 mm
F1.115	115 mm	122 - 160 mm
F1.150	150 mm	157 - 195 mm
F1.185	185 mm	192 - 230 mm
F1.220	220 mm	227 - 265 mm
F1.255	255 mm	262 - 300 mm

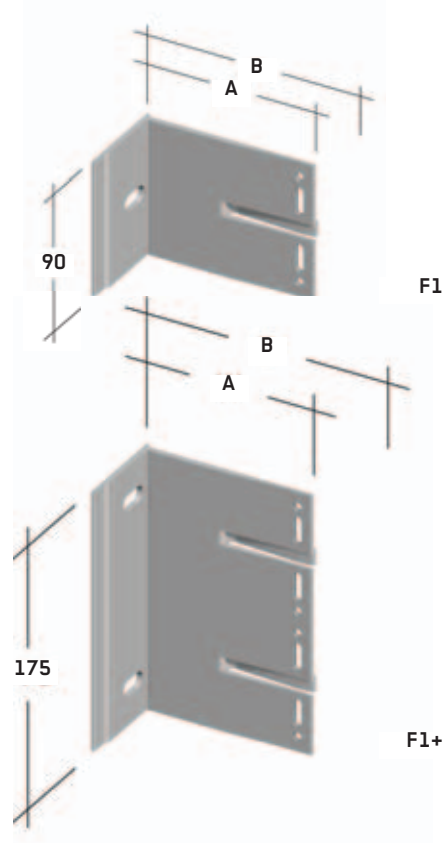

WALL BRACKET F2

The wall bracket F2 is mainly used for horizontal fixings on beam- and column constructions.

Technical Features/Benefits:

- High bearing capacity due to the design
- Developed for mounting on beam- and column structures
- Each F2 can be used for a fixed point or a sliding point. The F2+ is mainly used as a fixed point due to the high load suspension and 4 wall mountings.
- Integrated clamp-slide provides 40 mm of adjusting for the horizontal profiles.
- Made of aluminium EN-AW 6060 T68

Wall Bracket	Throat depth A	Distance to Wall B
F2.80	80 mm	117 - 155 mm
F2.115	115 mm	152 - 190 mm
F2.150	150 mm	187 - 225 mm
F2.185	185 mm	222 - 260 mm
F2.220	220 mm	257 - 295 mm
F2.255	255 mm	292 - 330 mm
F2.290	290 mm	327 - 365 mm

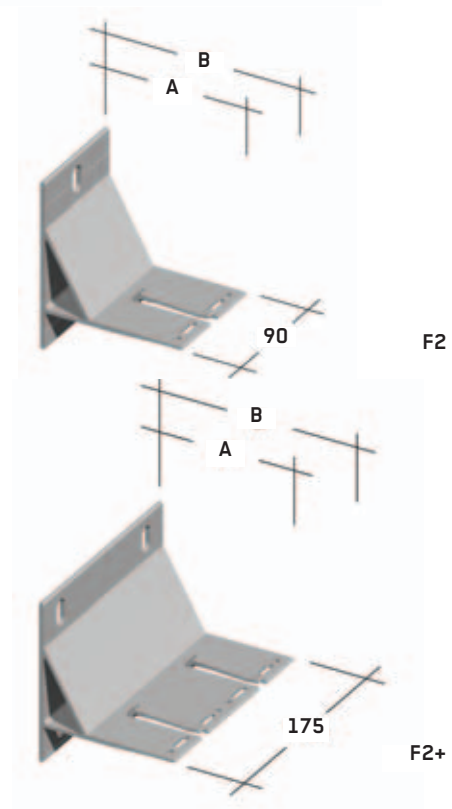

ALLFACE SYSTEM BASICS

Basically, fixing systems are differentiated according to visible or concealed fastening and horizontal or vertical fixing.

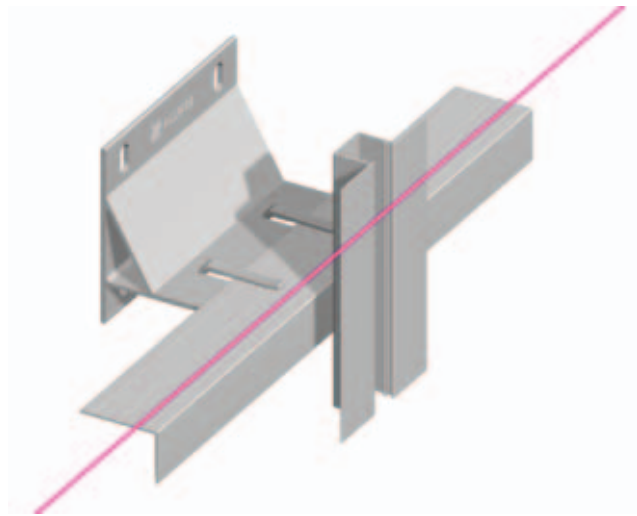
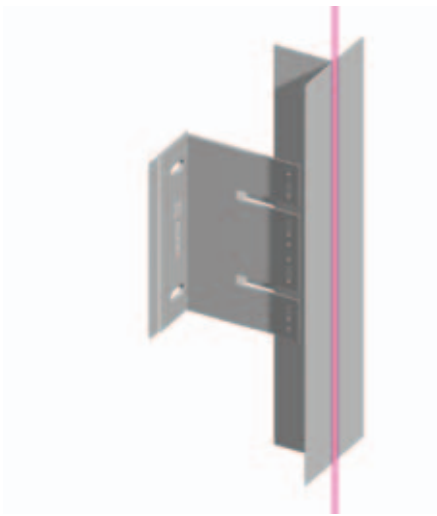

VERTICAL SYSTEMS

Vertical systems are used for mounting on solid walls. The primary profile is mounted vertically on an F1.

HORIZONTAL SYSTEMS

For constructions made of beam- and column structures, horizontal systems are used exclusively in which the primary profile is mounted horizontally on an F2.

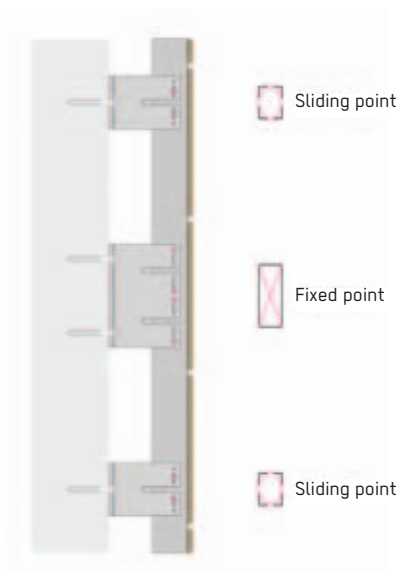

THERMAL LINEAR EXPANSION

When mounting vertical or horizontal systems, temperature-related linear expansion of the profiles must be taken into consideration. For this reason, the elongated holes of the wall brackets allow for thermal expansion of the section. The length of the profiles is determined by the storey- height or panel separation.



FIXED POINT

The fixed point passes the dead weight and wind loads to the load-bearing wall. The connection between the wall bracket and profile is therefore implemented immovably in the "round holes".

For connections of primary profiles and carrier rails, fixed and sliding points are also used for fastening.

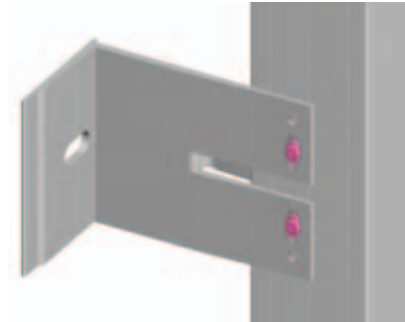

SLIDING POINT

In contrast, the connection between a sliding point and the profile is designed to be a sliding connection in elongated holes. As a result, the profile is not impeded in the event of length changes and there are no jammed connections.

For a sliding point, only wind pressure loads are passed to the load bearing wall.



FIXED POINT



SLIDING POINT

TYPE OF FIXING

Type of Fastening	Fastening Materials	Smart Fixing Systems
visible	Rivets	F1.10
visible	Rivets	F2.10
visible	Clamps	F1.20
visible	Clamps	F2.20
concealed	Adhesive system	F1.30
concealed	Adhesive system	F2.30
concealed	Undercut anchors	F1.40
concealed	Hooking-in system	F1.50
concealed	Hooking-in system	F2.50

THERMAL SEPARATION

In order to avoid thermal bridges or alternatively to minimise heat losses, thermal separation elements are built in between the wall bracket and the outside wall.

SMART FIXING SYSTEMS

VISIBLE FIXING WITH RIVETS

Facade fastening with rivets is a very economical method of installation due to the easy mounting. It is mainly used for metal, fibre cement and High Pressure Laminate - HPL facade elements.

SYSTEM F1.10

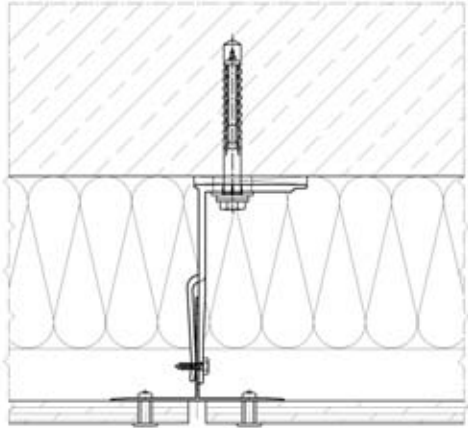
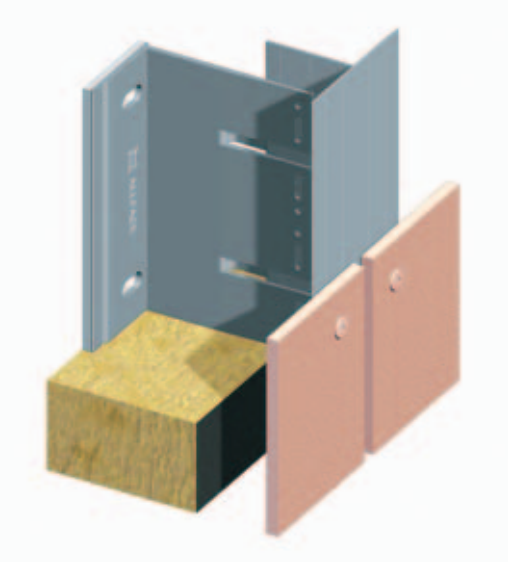

SYSTEM F2.10

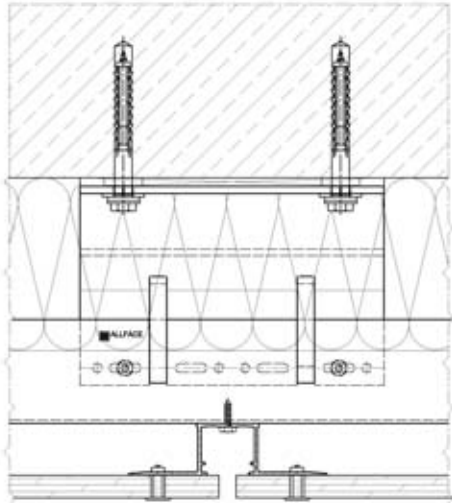
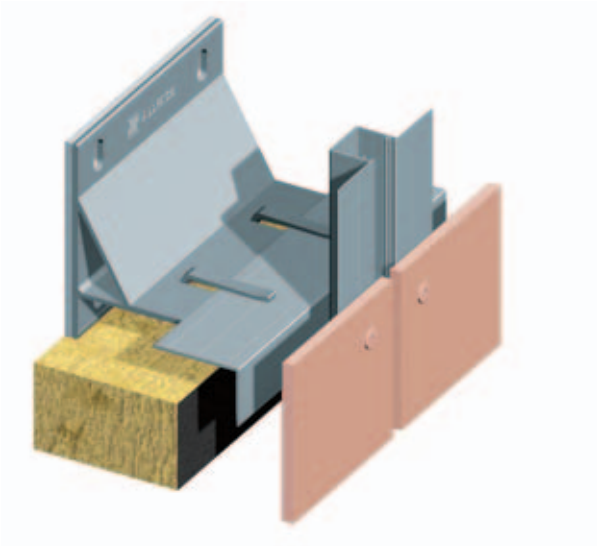

VISIBLE FIXING WITH CLAMPS

Fastening by means of clamps is used in particular for ceramic and terracotta facade elements. The clamps are available in aluminium and stainless steel and can be made to match the colour of the facade elements.

SYSTEM F1.20

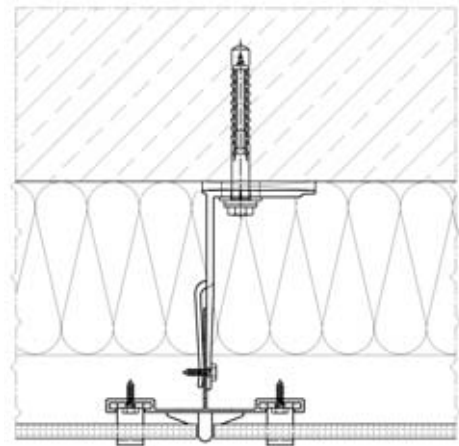
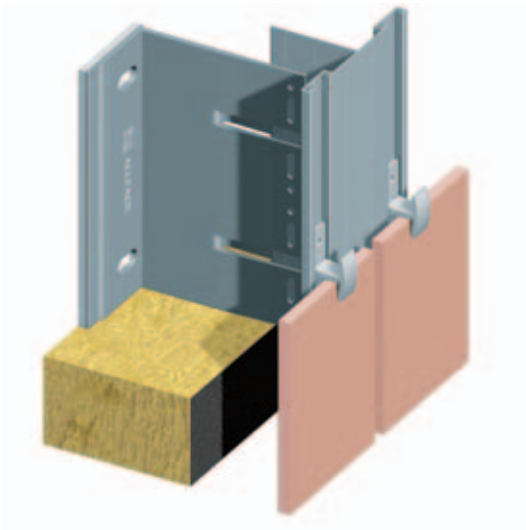

SYSTEM F2.20

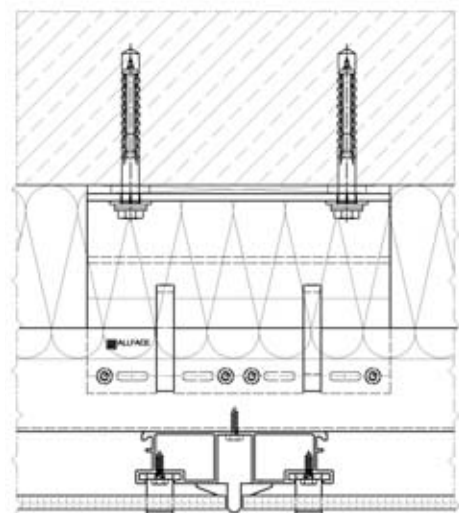
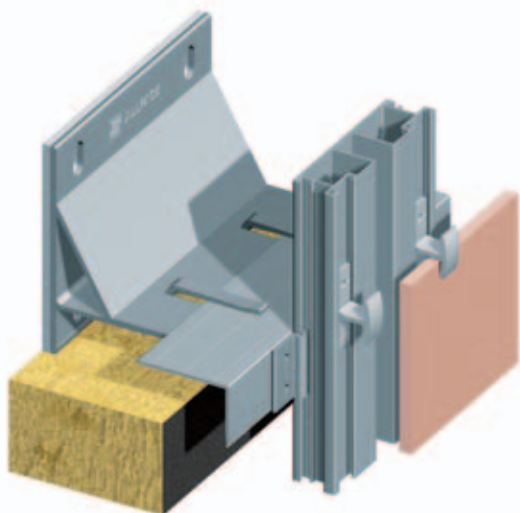

CONCEALED FIXING WITH ADHESIVE SYSTEM

Gluing facade panels is an economical mounting method. The panels are assembled on the properly pre-treated profiles with permanent elastic glue and with double-sided adhesive mounting tapes.

SYSTEM F1.30

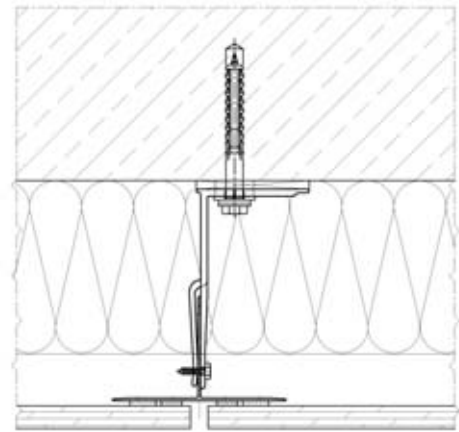
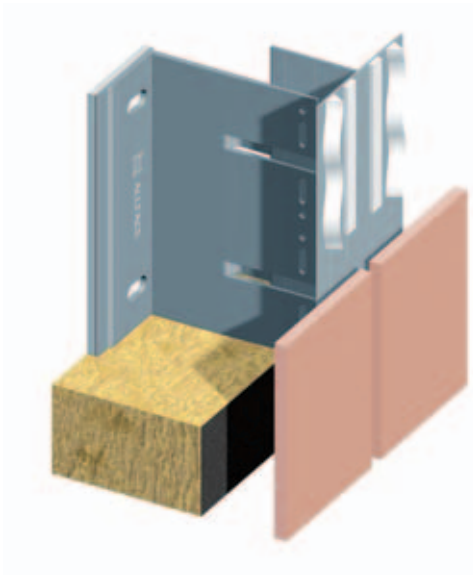

SYSTEM F2.30

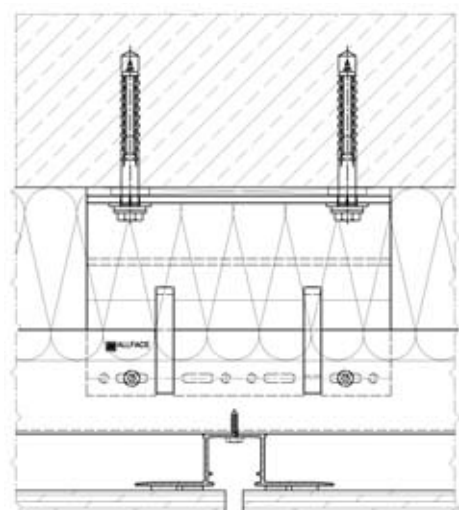
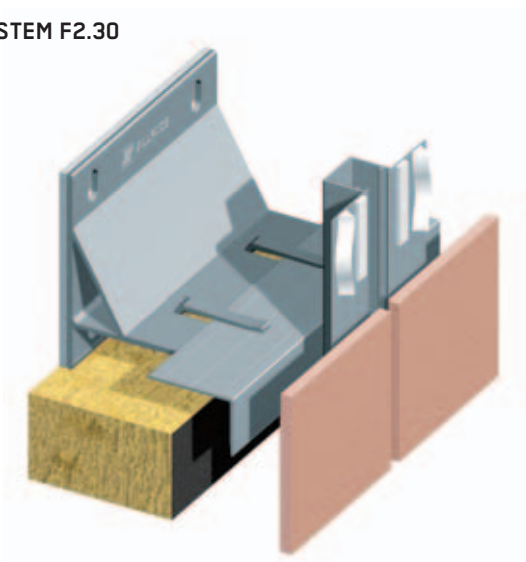

CONCEALED FIXING WITH UNDER-CUT ANCHORS

Facade panels can be fastened mechanically and concealed with the help of undercut anchors. Hanger elements are put into the undercut drill hole on the back of the panel with special dowels. Each facade panel is fastened with at least four individual hanger elements.

SYSTEM F1.40

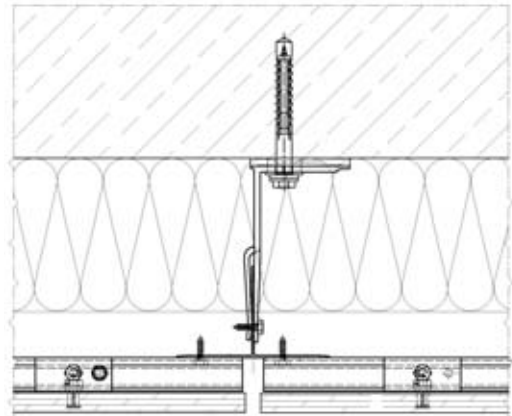
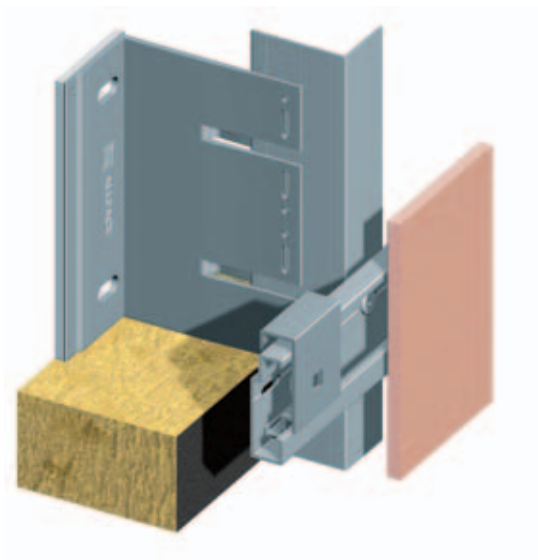

CONCEALED FIXING FOR HOOKING IN FACADE ELEMENTS

Fixing systems for hooking in facade elements have proven to be an efficient mounting method. Aluminium Composite (ACM) boards are especially well suited for this mounting method. To do this, the ACM boards are processed into cassettes and hooked into the fixing system and then secured against slipping.

SYSTEM F1.50

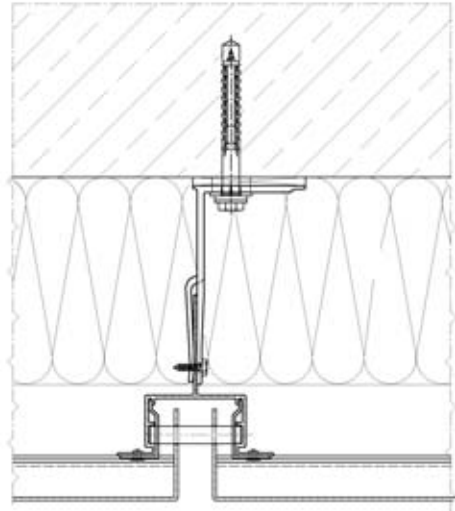

SYSTEM F2.50

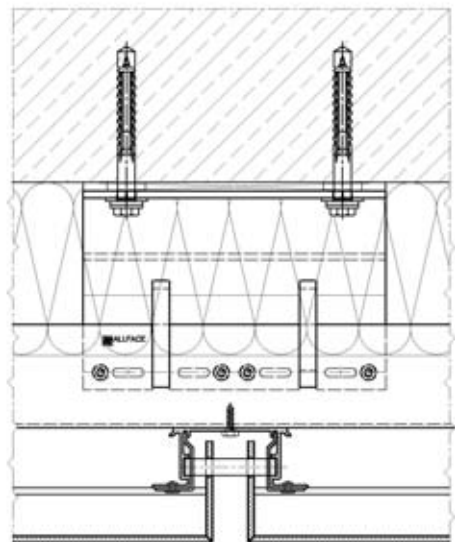
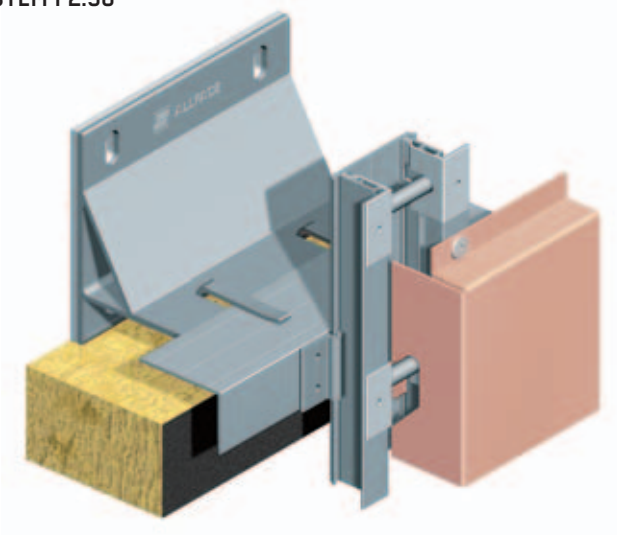



WORLDWIDE SUPPORT

We simplify the complexity of facade design. The determination of the optimal fixing solution based on your detailed project information is done by us.

With our statics calculation programme, we comply with the required safety requirements and optimise the quantity of fixing elements that are used. That way, we contribute to the economic efficiency of the project.

Starting with the statics of the target, the installation plans are prepared for clear, easy, and quick fastening.

By maintaining an open dialogue with our customers, we are able to point out difficulties and possible improvements above all in the planning stage and that way help to save costs.

To help prepare your plans, we would be happy to provide CAD drawings with system details.

In addition, we will give you the appropriate templates for the specification.

We advise facade manufacturers and architects with regard to general and specific themes of Rainscreen and we train customer and installation teams onsite.

The necessary proximity to the customer is achieved through our international sales network. The benefit to our customers is our standard for quality and service. And, we act accordingly.

Project Information Form

To prepare a meaningful offer, we need you to fill out the project information form. (See the project information form at www.allface.com » downloads)

Guarantee

All systems are manufactured in accordance with EN 12020 and EN 755 and are statically provable. Allface is not liable for deficiencies in the facade elements or the installation. Local building regulations must be met.

Subject to technical changes.

© Allface 2006
Graphics: TextDesign
Version: 1/06 en



ALLFACE Befestigungstechnologie GmbH & CoKG
A-2544 Leobersdorf, Aredstraße 29 Office 222

T +43(0)2256/625 18
F +43(0)2256/625 18 18
e office@allface.com
www.allface.com

